



MFS1S00-HxxxV 200Gb/s QSFP56 MMF AOC Product Specifications

Table of Contents

Introduction.....	3
Key Features.....	3
Applications.....	3
Pin Description	4
QSFP56 Pin Description	4
QSFP56 Module Pad Layout.....	5
Control Signals	5
Diagnostics and Other Features.....	6
Handling Precautions and Electrostatic Discharge (ESD).....	6
Specifications.....	7
Absolute Maximum Specifications.....	7
Environmental Specifications	7
Operational Specifications	7
Electrical Specifications	7
Interoperability	8
Rate Select.....	8
Rate Select Encodings.....	8
Mechanical Specifications	8
Mechanical Dimensions for Option 1	9
Cable Length Definition for Option 1	9
Mechanical Dimensions for Option 2	9
Cable Length Definition for Option 2	10
Mechanical Dimensions for Option 3	10
Labels.....	10
Backshell Label.....	11
Back-Shell Label Legend	11
Regulatory Compliance and Classification	12
FCC Class A Notice	12
Ordering Information	13
References	14
Document Revision History	15

Introduction

The NVIDIA® MFS1S00 is a QSFP56 VCSEL-based (Vertical Cavity Surface-Emitting Laser) active optical cable (AOC) designed for use in 200Gb/s InfiniBand (IB) HDR (High Data Rate) systems. The MFS1S00 AOC offers high port density and configurability, and a much longer reach than passive copper cables in the data centers. Since the AOC is hot pluggable, it is easy to install and replace.

The MFS1S00 has a standard SFF-8665 compliant QSFP56 port on the electrical side towards the host system. It contains four multi-mode fibers (MMF) optic transceivers per end, each operating at data rates of up to 50Gb/s.

The MFS1S00 offers selectable retiming per lane for both its optical transmitters and receivers up to 50Gb/s rates.

NVIDIA's unique quality cable solutions provide power-efficient connectivity for data center interconnects. It enables higher port bandwidth, density and configurability at a low cost, and reduced power requirement in the data centers. Rigorous production testing ensures the best out-of-the-box installation experience, performance and durability.



 Images are for illustration purposes only. Product labels, colors, and lengths may vary.

Key Features

- Supports IBTA IB HDR
- Up to 200Gb/s
- 4x 50Gb/s PAM4 modulation
- Programmable Rx output amplitude and pre-emphasis
- SFF-8665 compliant QSFP56 port
- Single 3.3V power supply
- 5.0W power consumption (typ., each end, with retiming)
- Up to 100m length
- Hot pluggable
- RoHS compliant
- SFF-8636 compliant I²C management interface

Applications

- Supports 200Gb InfiniBand HDR Systems
- Supports 200 GbE between SN3700 and SN4600 switches

Pin Description

The Active Optical Cable) pin assignment is SFF-8679 compliant.

QSFP56 Pin Description

Pin	Symbol	Description	Pin	Symbol	Description
1	GND	Ground	20	GND	Ground
2	Tx2n	Transmitter Inverted Data Input	21	Rx2n	Receiver Inverted Data Output
3	Tx2p	Transmitter Non-Inverted Data Input	22	Rx2p	Receiver Non-Inverted Data Output
4	GND	Ground	23	GND	Grounds
5	Tx4n	Transmitter Inverted Data Input	24	Rx4n	Receiver Inverted Data Output
6	Tx4p	Transmitter Non-Inverted Data Input	25	Rx4p	Receiver Non-Inverted Data Output
7	GND	Ground	26	GND	Ground
8	ModSelL	Module Select	27	ModPrsL	Module Present
9	ResetL	Module Reset	28	IntL	Interrupt
10	Vcc Rx	+3.3V Power Supply Receiver	29	Vcc Tx	+3.3V Power Supply Transmitter
11	SCL	2-wire Serial Interface Clock	30	Vcc1	+3.3V Power Supply
12	SDA	2-wire Serial Interface Data	31	LPMode	Low Power Mode
13	GND	Ground	32	GND	Ground
14	Rx3p	Receiver Non-Inverted Data Output	33	Tx3p	Transmitter Non-Inverted Data Input
15	Rx3n	Receiver Inverted Data Output	34	Tx3n	Transmitter Inverted Data Input
16	GND	Ground	35	GND	Ground
17	Rx1p	Receiver Non-Inverted Data Output	36	Tx1p	Transmitter Non-Inverted Data Input
18	Rx1n	Receiver Inverted Data Output	37	Tx1n	Transmitter Inverted Data Input
19	GND	Ground	38	GND	Ground

QSFP56 Module Pad Layout

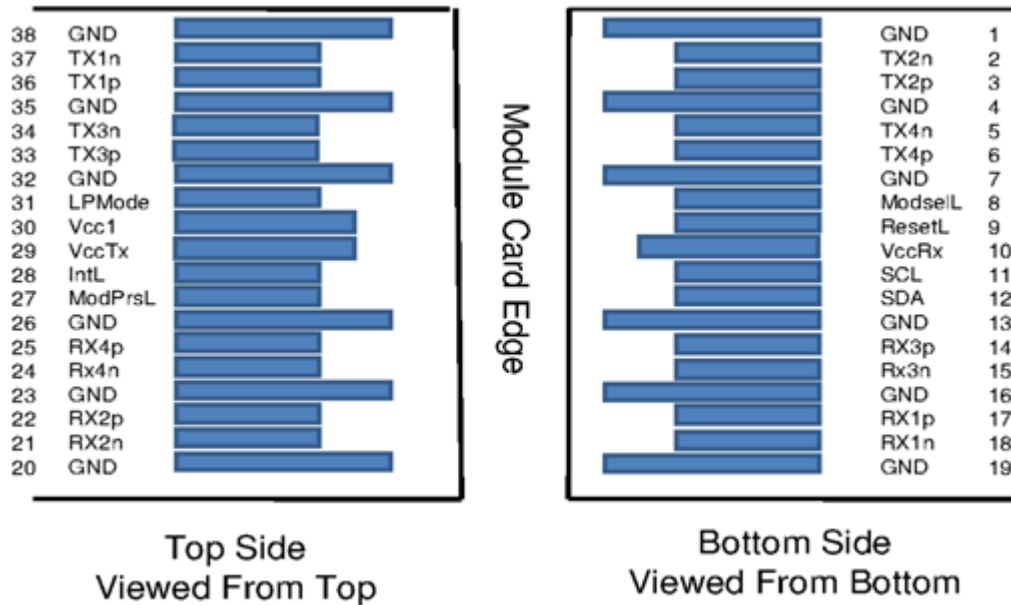

Control Signals

This transceiver is SFF-8636 compliant. This means that the control signals shown in the pad layout support the following functions:

ModPrsL	Module Present pin, grounded inside the module. Terminated with pull-up in the host system. Asserted low when the transceiver is inserted, whereby the host detects the presence of the transceiver.
ModSelL	Module Select input pin, terminated high in the module. Only when held low by the host, the module responds to 2-wire serial communication commands. The ModSelL enables multiple modules to share a single 2-wire interface bus.
ResetL	Reset input pin, pulled high in the module. A low level on the ResetL pin for longer than the minimum pulse length (t_{Reset_init}) initiates a complete module reset, returning all user module settings to their default state. During reset the host shall disregard all status bits until the module indicates completion of the reset interrupt by asserting IntL signal low with the Data_Not_Ready bit negated. Note that on power up (including hot insertion) the module completes the reset interrupt without requiring a reset.
LPMode	Low Power Mode input, pulled up inside the module. The transceiver starts up in low-power mode, i.e. <1.5 W with the two-wire interface active. The host system can read the power class declaration from the transceiver and determine if it has enough power to enable the high-speed operation/high power mode of the transceiver. This can be done by asserting LPMode low or by use of the Power_over-ride and Power_set control bits (Address A0h, byte 93 bits 0,1).
IntL	Interrupt Low is an open-collector output, terminated high in the host system. A “Low” indicates a possible module operational fault or a status critical to the host system, e.g. temperature alarm. The host identifies the source of the interrupt using the 2-wire serial interface. The INTL pin is de-asserted “High” after completion of reset, when byte 2 bit 0 (Data Not Ready) is read with a value of ‘0’.

The low-speed signals are Low Voltage TTL (LVTTTL) compliant (except for SCL and SDA signals).

Diagnostics and Other Features

The transceiver complies with the SFF-8665 specification and has the following key features:

Physical layer link optimization:

- Programmable Tx input equalization
- Programmable Rx output amplitude
- Programmable Rx output pre-emphasis
- Tx/Rx CDR control
by default enabled for 100 GbE operation, disable it for 40G operation

Digital Diagnostic Monitoring (DDM):

- Rx receive optical power monitor for each lane
- Tx transmit optical power monitor for each lane
- Tx bias current monitor for each lane
- Supply voltage monitor
- Transceiver case temperature monitor
- Warning and Alarm thresholds for each DDM function (not user changeable)

Other SFF-8636 functions and interrupt indications:

- Tx & Rx LOS indication
- Tx & Rx LOL indication
- Tx fault indication

LOS, LOL, and Tx Fault status flags can be read via the two-wire management interface and are jointly transmitted via the IntL output pin. Relevant advertisement, threshold, and readout registers are found in the SFF-8636 MSA.

Handling Precautions and Electrostatic Discharge (ESD)

The MFS1500-HxxxV is compatible with ESD levels in typical data center operating environments and certified in accordance with the standards listed in the [Regulatory Compliance Section](#). The product is shipped with protective caps on its connectors to protect it until the time of installation. In normal handling and operation of high-speed cables and optical transceivers, ESD is of concern during insertion into the QSFP cage of the server/switch. Hence, standard ESD handling precautions must be observed. These include use of grounded wrist/shoe straps and ESD floor wherever a cable/transceiver is extracted/inserted. Electrostatic discharges to the exterior of the host equipment chassis after installation are subject to system level ESD requirements.

Specifications

Absolute Maximum Specifications

Absolute maximum ratings are those beyond which damage to the device may occur.

Prolonged operation between the operational specifications and absolute maximum ratings is not intended and may cause permanent device degradation.

Parameter	Min	Max	Units
Supply voltage	-0.3	3.6	V
Data input voltage	-0.3	3.465	V
Control input voltage	-0.3	4.0	V
Damage Threshold	3.4	---	dBm

Environmental Specifications

This table shows the environmental specifications for the product.

Parameter	Min	Max	Units
Storage temperature	-40	85	°C

Operational Specifications

This section shows the range of values for normal operation. The host board power supply filtering should be designed as recommended in the SFF Committee Spec.

Parameter	Min	Typ	Max	Units
Supply voltage (V_{CC})	3.135	3.3	3.465	V
Power dissipation (each end, retiming on all lanes)	---	4.8	5.0	W
Supply noise tolerance (10Hz - 10MHz)	66	---	---	mVpp
Operating case temperature	0	---	70 ¹	°C
Operating relative humidity	5	---	85	%

1. Internal temperature readout through DDMI of up to 75°C is allowed.

Electrical Specifications

Parameter	Min	Typ	Max	Units
Signaling rate	-100 ppm	53.125	+100 ppm	Gb/s (PAM4)
	-100 ppm	25.78125	+100 ppm	Gb/s (NRZ)

Parameter	Min	Typ	Max	Units
Differential data input swing at TP1a	TBD	---	900	mVpp
Differential data output swing at TP4	---	---	900	mVpp
Near-end ESMW	0.265	---	---	UI
Near-end output eye height	70	---	---	mVpp
Output transition time, 20% to 80%	9.5	---	---	ps

Notes:

- Multiple clock domains are supported only on line-side Rx. Host side Rx supports a single clock domain only.
- QSFP Tx CDR lock can only occur if Tx lane 1 is transmitting data (Does not apply to [option 1](#)).

Interoperability

For configurations tested with the AOCs, please refer to the system level product (SLP) qualification report.

Rate Select

The AOC supports rate select, which is controlled by writing to registers 0x57-0x58. Two bits are assigned for each receiver lane in byte 0x57 (87dec, Rxn_Rate_Select) and two bits for each transmitter lane in byte 0x58 (88dec, Txn_Rate_Select) to specify up to four bitrates, as defined in SFF-8636 Rev 2.9.2 Table 6-5 XN_RATE_SELECT ENCODINGS. All four lanes are required to have the same rate select value.

The below table specifies the rate for each rate select setting.

Rate Select Encodings

Rate Select Value	Operating Rate (GBd)
10	25.78125 NRZ (EDR)
11	26.56250 PAM4 (HDR)

Mechanical Specifications

Parameter	Value		Units
Diameter	3 +/-0.2		mm
Minimum bend radius	30		mm
Length tolerance	length < 5 m	+300 /-0	mm
	5 m ≤ length < 50 m	+500 / -0	
	50 m ≤ length	+1000 /-0	

Parameter	Value	Units
Cable color	Aqua	---

Mechanical Dimensions for Option 1

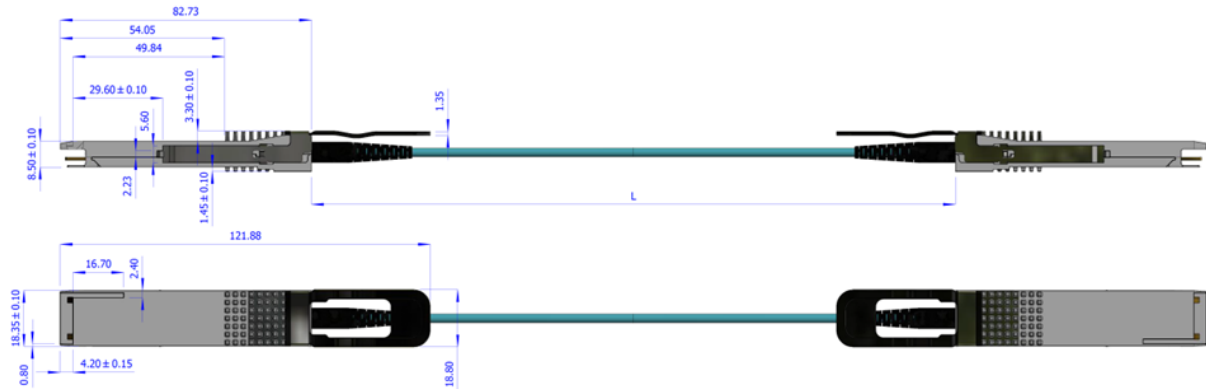

Cable Length Definition for Option 1

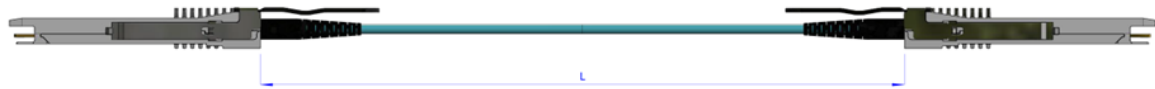

Mechanical Dimensions for Option 2

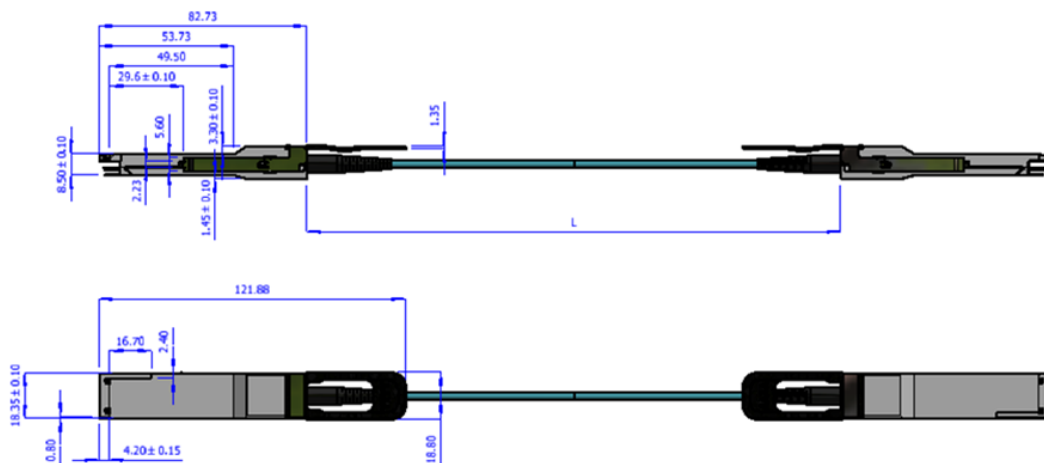

Cable Length Definition for Option 2

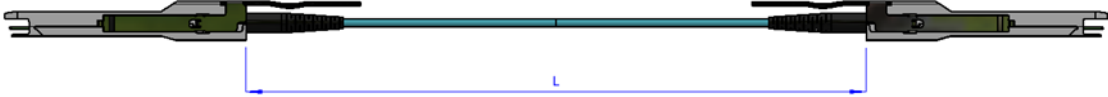

Mechanical Dimensions for Option 3

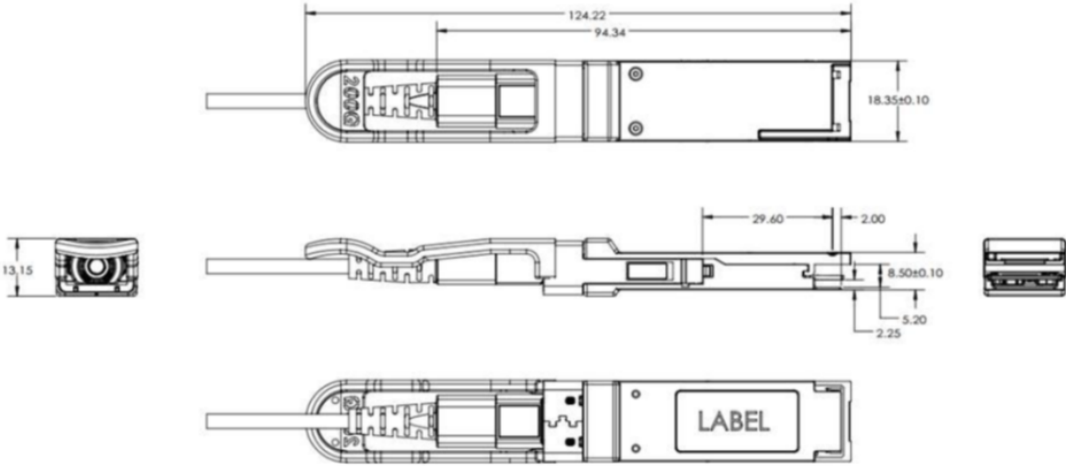



⚠ For option 3 of this product line, the earliest qualified firmware versions are E6 B1 and E6 B2.

Labels

The following label is applied on the transceiver's back-shell:

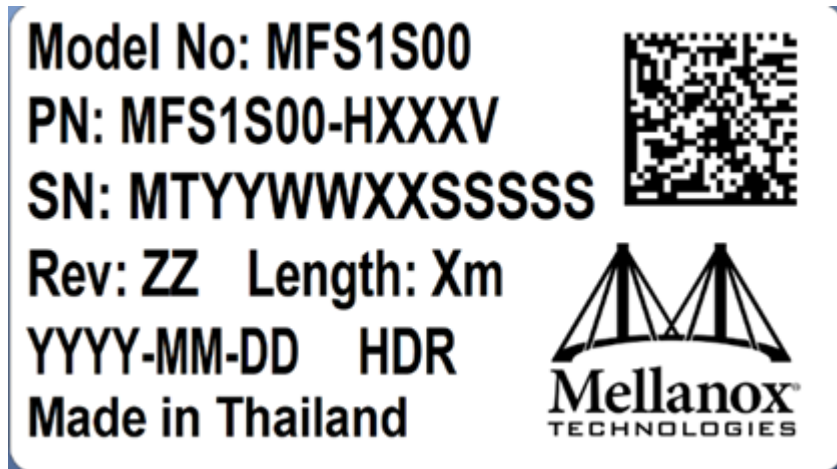
Backshell Label



 Images are for illustration purposes only. Product labels, colors, and lengths may vary.

Back-Shell Label Legend

Symbol	Meaning	Notes
PN - Part Number		
xxx	Length	Meter
SN - Serial Number		
MT	Manufacturer name	2 characters, e.g. MT
YY	Year of manufacturing	2 digits
WW	Week of manufacturing	2 digits
XX	Manufacturer site	2 characters
SSSSS	Serial number	5 digits for serial number, starting from 00001. Reset at start of week to 00001.
Miscellaneous		
ZZ	HW and SW revision	2 alpha-numeric characters
Xm	Cable length	Meter
YYYY	Year of manufacturing	4 digits
MM	Month of manufacturing	2 digits
DD	Day of manufacturing	2 digits
COO	Country of origin	E.g. China or Thailand
	Quick response code	Serial number

The following label is applied on the cable's jacket:

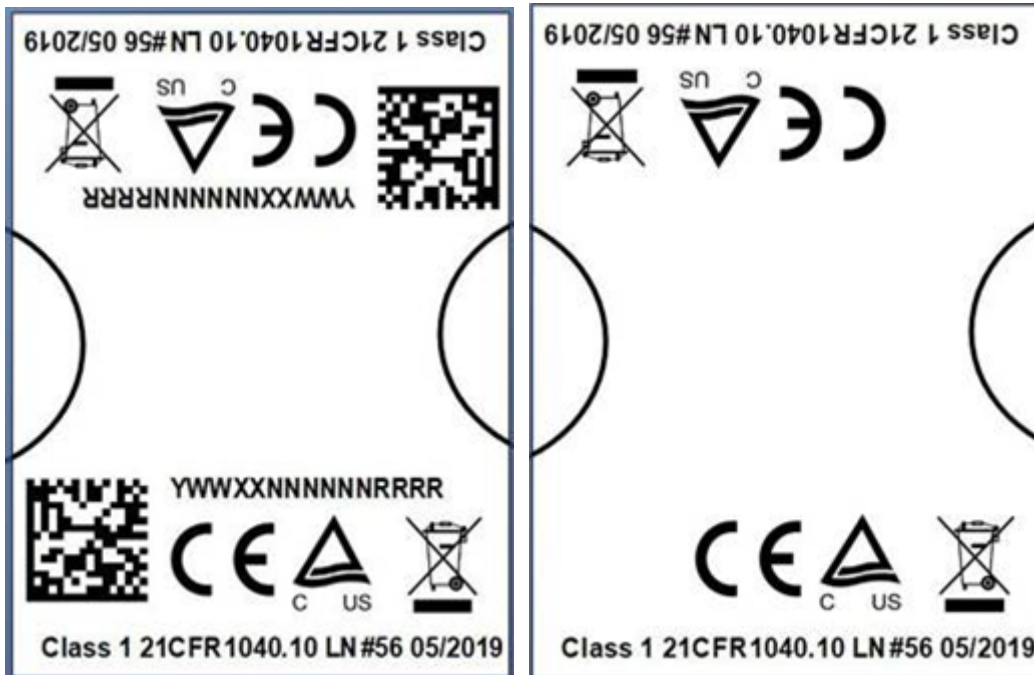

⚠ The serial number and barcode are for NVIDIA internal use only. Different layouts of this label apply to different production series. It has no effect on the cable's performance nor function. Images are for illustration purposes only. Product labels, colors, and lengths may vary.

Regulatory Compliance and Classification

The laser module is classified as class I according to IEC 60825-1, IEC 60825-2 and 21 CFR 1040 (CDRH).

- Safety: CB, cTUVus, CE
- EMC: CE, FCC, ICES, RCM, VCCI

Ask your NVIDIA FAE for a zip file of the certifications for this product.

FCC Class A Notice

This equipment has been tested and found to comply with the limits for a Class A digital device, pursuant to part 15 of the FCC Rules. These limits are designed to provide reasonable protection against harmful interference when the equipment is operated in a commercial environment. This equipment generates, uses, and can radiate radio frequency energy and, if not installed and used in accordance with the instruction manual, may cause harmful interference to radio communications. Operation of this equipment in a residential area is likely to cause harmful interference in which case the user will be required to correct the interference at his own expense.



Ordering Information

Ordering Part Number	Description
MFS1S00-H003V	Active optical cable, up to 200Gb/s VPI (IB HDR & 200GbE), QSFP56, 3m
MFS1S00-H005V	Active optical cable, up to 200Gb/s VPI (IB HDR & 200GbE), QSFP56, 5m
MFS1S00-H010V	Active optical cable, up to 200Gb/s VPI (IB HDR & 200GbE), QSFP56, 10m
MFS1S00-H015V	Active optical cable, up to 200Gb/s VPI (IB HDR & 200GbE), QSFP56, 15m
MFS1S00-H020V	Active optical cable, up to 200Gb/s VPI (IB HDR & 200GbE), QSFP56, 20m
MFS1S00-H030V	Active optical cable, up to 200Gb/s VPI (IB HDR & 200GbE), QSFP56, 30m
MFS1S00-H050V	Active optical cable, up to 200Gb/s VPI (IB HDR & 200GbE), QSFP56, 50m
MFS1S00-H100V	Active optical cable, up to 200Gb/s VPI (IB HDR & 200GbE), QSFP56, 100m

Please see [here](#) for the cable length definition.

References

- QSFP Quad Small Form Factor Pluggable - Concept: SFF-8665:
<https://www.snia.org/technology-communities/sff/specifications>
- QSFP Quad Small Form Factor Pluggable - Management: SFF-8636:
<https://www.snia.org/technology-communities/sff/specifications>
- InfiniBand Architecture Specification and FAQ:
<https://www.infinibandta.org/ibta-specification/>
- Environmental and Regulatory compliance statements:
<https://www.mellanox.com/company/quality/regulatory-compliance/environmental>
- Nvidia Networking Cable Configurator:
<https://www.mellanox.com/products/interconnect/cables-configurator>
- Nvidia Cable Management Guide and FAQ:
<https://mymellanox.force.com/support/servlet/fileField?id=0BE1T000000TcKC>

For documentation, please contact your sales representative or the Support team.

Document Revision History

Revision	Date	Description
1.3	Jan. 2023	Updated OPNs description in Ordering Information.
1.2	Apr. 2022	Added a note to Mechanical Dimensions for Option 3.
1.1	Nov. 2021	Reformatted and rebranded; migrated to HTML.
1.0	Oct. 2021	First release.

Notice

This document is provided for information purposes only and shall not be regarded as a warranty of a certain functionality, condition, or quality of a product. Neither NVIDIA Corporation nor any of its direct or indirect subsidiaries and affiliates (collectively: "NVIDIA") make any representations or warranties, expressed or implied, as to the accuracy or completeness of the information contained in this document and assumes no responsibility for any errors contained herein. NVIDIA shall have no liability for the consequences or use of such information or for any infringement of patents or other rights of third parties that may result from its use. This document is not a commitment to develop, release, or deliver any Material (defined below), code, or functionality.

NVIDIA reserves the right to make corrections, modifications, enhancements, improvements, and any other changes to this document, at any time without notice.

Customer should obtain the latest relevant information before placing orders and should verify that such information is current and complete.

NVIDIA products are sold subject to the NVIDIA standard terms and conditions of sale supplied at the time of order acknowledgement, unless otherwise agreed in an individual sales agreement signed by authorized representatives of NVIDIA and customer ("Terms of Sale"). NVIDIA hereby expressly objects to applying any customer general terms and conditions with regards to the purchase of the NVIDIA product referenced in this document. No contractual obligations are formed either directly or indirectly by this document.

NVIDIA products are not designed, authorized, or warranted to be suitable for use in medical, military, aircraft, space, or life support equipment, nor in applications where failure or malfunction of the NVIDIA product can reasonably be expected to result in personal injury, death, or property or environmental damage. NVIDIA accepts no liability for inclusion and/or use of NVIDIA products in such equipment or applications and therefore such inclusion and/or use is at customer's own risk.

NVIDIA makes no representation or warranty that products based on this document will be suitable for any specified use. Testing of all parameters of each product is not necessarily performed by NVIDIA. It is customer's sole responsibility to evaluate and determine the applicability of any information contained in this document, ensure the product is suitable and fit for the application planned by customer, and perform the necessary testing for the application in order to avoid a default of the application or the product. Weaknesses in customer's product designs may affect the quality and reliability of the NVIDIA product and may result in additional or different conditions and/or requirements beyond those contained in this document. NVIDIA accepts no liability related to any default, damage, costs, or problem which may be based on or attributable to: (i) the use of the NVIDIA product in any manner that is contrary to this document or (ii) customer product designs.

No license, either expressed or implied, is granted under any NVIDIA patent right, copyright, or other NVIDIA intellectual property right under this document. Information published by NVIDIA regarding third-party products or services does not constitute a license from NVIDIA to use such products or services or a warranty or endorsement thereof. Use of such information may require a license from a third party under the patents or other intellectual property rights of the third party, or a license from NVIDIA under the patents or other intellectual property rights of NVIDIA.

Reproduction of information in this document is permissible only if approved in advance by NVIDIA in writing, reproduced without alteration and in full compliance with all applicable export laws and regulations, and accompanied by all associated conditions, limitations, and notices.

THIS DOCUMENT AND ALL NVIDIA DESIGN SPECIFICATIONS, REFERENCE BOARDS, FILES, DRAWINGS, DIAGNOSTICS, LISTS, AND OTHER DOCUMENTS (TOGETHER AND SEPARATELY, "MATERIALS") ARE BEING PROVIDED "AS IS." NVIDIA MAKES NO WARRANTIES, EXPRESSED, IMPLIED, STATUTORY, OR OTHERWISE WITH RESPECT TO THE MATERIALS, AND EXPRESSLY DISCLAIMS ALL IMPLIED WARRANTIES OF NON-INFRINGEMENT, MERCHANTABILITY, AND FITNESS FOR A PARTICULAR PURPOSE. TO THE EXTENT NOT PROHIBITED BY LAW, IN NO EVENT WILL NVIDIA BE LIABLE FOR ANY DAMAGES, INCLUDING WITHOUT LIMITATION ANY DIRECT, INDIRECT, SPECIAL, INCIDENTAL, PUNITIVE, OR CONSEQUENTIAL DAMAGES, HOWEVER CAUSED AND REGARDLESS OF THE THEORY OF LIABILITY, ARISING OUT OF ANY USE OF THIS DOCUMENT, EVEN IF NVIDIA HAS BEEN ADVISED OF THE POSSIBILITY OF SUCH DAMAGES. Notwithstanding any damages that customer might incur for any reason whatsoever, NVIDIA's aggregate and cumulative liability towards customer for the products described herein shall be limited in accordance with the Terms of Sale for the product.

Trademarks

NVIDIA, the NVIDIA logo, and Mellanox are trademarks and/or registered trademarks of NVIDIA Corporation and/or Mellanox Technologies Ltd. in the U.S. and in other countries. Other company and product names may be trademarks of the respective companies with which they are associated.



Copyright

© 2023 NVIDIA Corporation & affiliates. All Rights Reserved.

